

PREMIA ES

Pedestrian Power Pallet • AC Power
1.6 – 2.0 tonnes

PBP16N2
PBP18N2
PBP20N2
PBP20N2R
PBP20N2E

Exceptional performance... whatever the conditions

Developed for non-stop performance in the most challenging environments and the tightest spaces, PREMIA ES pedestrian power pallet trucks offer you a comprehensive range of transfer possibilities. Whether you are upgrading from a hand pallet truck, doing short shuttle work or looking for a truck prepared to go the distance, there is a PREMIA model which will meet your needs.

High stability and a market-leading lift height allow easy operation on uneven surfaces. Outdoor operation is possible in all weather thanks to protection of the chassis and electrical systems against rain and splashing water. Low-maintenance design, with no vulnerable components, minimises the chance of breakdown and lowers servicing costs.

For extra versatility, operators may choose between two performance modes via the key switch. In all models the state-of-the-art, simple-to-use tiller arm design protects hands and places everything within easy reach for safe, comfortable, controlled operation.

The PBP20N2R model includes a foldable platform for occasional ride-on use, while the PBP20N2E offers rising forks for easy loading and unloading.

Frame and body

- **Sealed chassis** offers protection against dirt, dust and other particles to reduce wear.
- **Water-resistant design** diverts splashed moisture away from key electrical components, for long truck life.
- **High stability** is ensured by use of two linked castor wheels – next to the central drive wheel – in addition to the load wheels.
- **Low centre of gravity** adds further stability, for safe operation.

Forks

- **Robust forks** with welded construction, and rounded tips for effortless pallet entry, give extra strength and durability.
- **Market-leading lift height** of 135 mm allows easy handling on steep ramps and loading docks, even with damaged pallets.
- **Rising forks** on PBP20N2E place loads at an ergonomic height - maximum 735 mm - for loading & unloading with minimal physical strain.



PREMIA ES

Pedestrian Power Pallet

AC Power • 1.6 – 2.0 tonnes

Characteristics				
1.1	Manufacturer (abbreviation)		Mitsubishi	Mitsubishi
1.2	Manufacturer's model designation		PBP16N2	PBP18N2
1.3	Power source (battery, diesel, LP gas, petrol)		Battery	Battery
1.4	Operator type: pedestrian, (operator)-standing, -seated		Pedestrian	Pedestrian
1.5	Load capacity	Q (kg)	1600	1800
1.6	Load centre distance	c (mm)	600	600
1.8	Load wheel axle to fork face (forks lowered)	x (mm)	960	960
1.9	Wheelbase	y (mm)	1360	1424
Weight				
2.1	Truck weight with maximum battery weight	kg	431	502
2.2	Axle loadings with nominal load & maximum battery weight, drive/load side	kg	635 / 1396	806 / 1496
2.3	Axle loadings without load & with maximum battery weight, drive/load side	kg	332 / 99	381 / 121
Wheels, Drive Train				
3.1	Tyres: PT=Power Thane, Vul=Vulkollan, drive/load side		Vul/Vul	Vul/Vul
3.2	Tyre dimensions, drive side	(mm)	230 × 70	230 × 70
3.3	Tyre dimensions, load side	(mm)	85 × 90	85 × 75
3.4	Castor wheel dimensions (diameter x width)	(mm)	100 × 40	100 × 40
3.5	Number of the wheels drive/load side (x=driven)		2+1x / 2	2+1x / 4
3.6	Track width (centre of tyres), drive side	b10 (mm)	480	480
3.7	Track width (centre of tyres), load side	b11 (mm)	355 / 375 / 495	355 / 375 / 495
Dimensions				
4.4	Lift height	h3 (mm)	135	135
4.6	Initial lift height	h5 (mm)	-	-
4.8	Seat- or stand height	h7 (mm)	-	-
4.9	Height of tiller arm / steering console (min/max)	h14 (mm)	1050 / 1372	1050 / 1372
4.15	Fork height, fully lowered	h13 (mm)	85	85
4.19	Overall length, platform up/down	l1 (mm)	1648	1712
4.20	Length to fork face, platform up/down	l2 (mm)	498	562
4.21	Overall width	b1/b2 (mm)	720	720
4.22	Fork dimensions (thickness,width,length)	s/e/l (mm)	55 / 165 / 1150	55 / 165 / 1150
4.25	Outside width over forks	b5 (mm)	520 / 540 / 660	520 / 540 / 660
4.32	Ground clearance, center of wheelbase (forks lowered)	m2 (mm)	30	30
4.33	Working aisle width (Ast) with 1000 x 1200 mm pallet, load crosswise, platform up/down	Ast (mm)	1694	1758
4.34	Working aisle width (Ast) with 800 x 1200 mm pallet,load lengthwise, platform up/down	Ast (mm)	1894	1958
4.35	Turning circle radius	Wa (mm)	1454	1518
Performance				
5.1	Travel speed, with/without load	km/h	6.0 / 6.0	6.0 / 6.0
5.2	Lifting speed, with/without load	m/s	0.035 / 0.045	0.035 / 0.045
5.3	Lowering speed, with/without load	m/s	0.05 / 0.05	0.05 / 0.05
5.7	Gradeability, with/without load	%	10.0 / 20.0	10.0 / 20.0
5.10	Service brakes (mechanical/hydraulic/electric/pneumatic)		Electric	Electric
Electric motors				
6.1	Drive motor capacity (60 min. short duty)	kW	1.0	1.0
6.2	Lift motor output at 15% duty factor	kW	0.8	0.8
6.4	Battery voltage/capacity at 5-hour discharge	V/Ah	24 / 150	24 / 250
6.5	Battery weight	kg	151	212
Miscellaneous				
8.1	Type of drive control		Stepless	Stepless
8.4**	Noise level, mean value at operator's ear (EN 12 053), drive/lift/idle	dB (A)	62 / 69 / 0	62 / 69 / 0
	Whole-body vibration (EN 13 059)	m/s ²	-	-
	Hand-arm vibration (EN 13 059)		< 2.5	< 2.5

* with 375Ah battery l2 dimension increases 72 mm

** Margin of error +/- 4 dB(A) in section 8.4

Continuing improvement may lead to changes in these specifications



Versatile battery compartment



Ergonomic load height (PBP20N2E)



Protective sealed chassis

PREMIA ES

THE NUMBER ONE

Number one for reliability... number one for productivity... whatever the conditions.

Compact, efficient and resilient, PREMIA powered pallet trucks meet every need.

PBP16/18/20N2

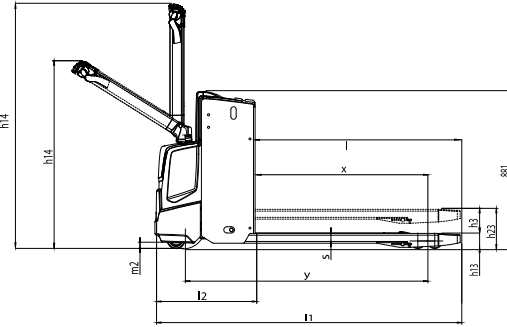
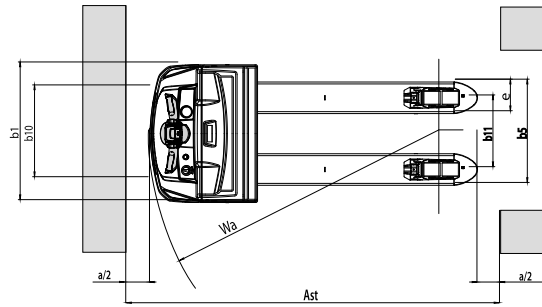

PBP20N2R: with folding platform

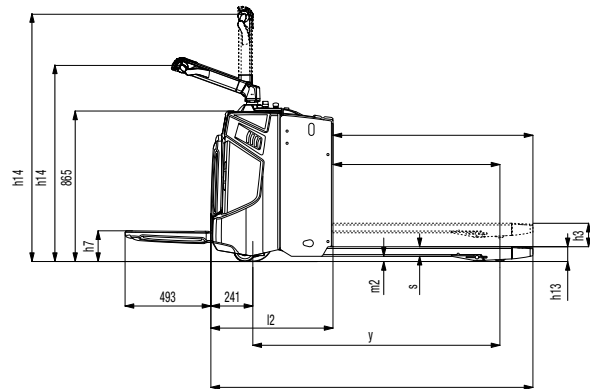
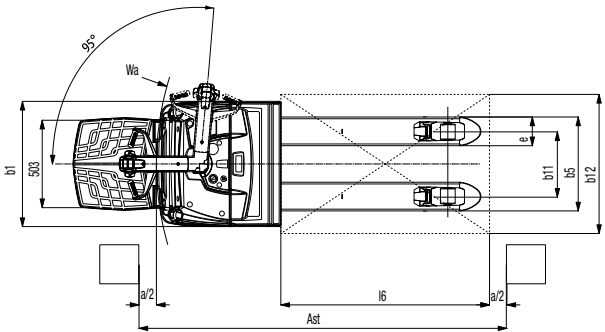

PBP20N2E: with rising forks

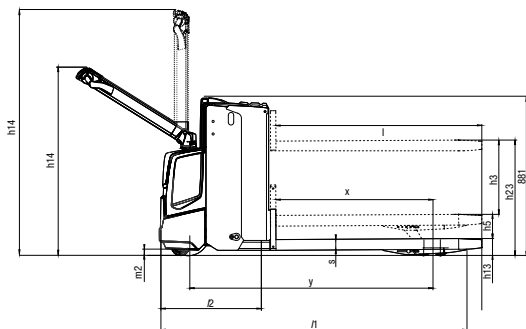

	Mitsubishi PBP20N2	Mitsubishi PBP20N2R	Mitsubishi PBP20N2E
	Battery	Battery	Battery
	Pedestrian	Pedestrian/Stand-on	Pedestrian
	2000	2000	2000 / 700
	600	600	600
	960	961	875
	1424	1433	1509
	634	595	579
	864 / 1770	890 / 1705	770 / 1809
	475 / 159	470 / 125	419 / 160
	Vul/Vul	Vul/Vul	Vul/Vul
	85 × 75	85 × 75	85 × 75
	230 × 70	230 × 70	230 × 70
	100 × 40	125 × 55	100 × 40
	2+1x /4	2+1x /4	2+1x /4
	480	480	480
	355 / 375 / 495	375	375
	135	135	510
	-	-	135
	-	172	-
	1050 / 1372	1180 / 1350	1050 / 1372
	85	85	90
	1712	1852 / 2346	1780
	562	702 / 1195	653
	720	720	720
	55 / 165 / 1150	50 / 165 / 1150	50 / 195 / 1150
	520 / 540 / 660	540	570
	30	30	30
	1758	1920 / 2400	1874
	1958	2120 / 2600	2074
	1518	1680 / 2160	1526
	6.0 / 6.0	6.0 / 6.0	6.0 / 6.0
	0.04 / 0.06	0.03 / 0.05	0.11 / 0.14
	0.05 / 0.05	0.07 / 0.08	0.13 / 0.12
	10.0 / 20.0	9.0 / 20.0	9.0 / 20.0
	Electric	Electric	Electric
	1.0	1.0	1.0
	1.2	1.2	1.2
	24 / 250-375*	24 / 250-375*	24 / 150
	212-294	212-294	151
	Stepless	Stepless	Stepless
	65 / 67 / 0	63 / 78 / 0	59 / 60 / 0
	-	0.9	-
	< 2.5	< 2.5	< 2.5

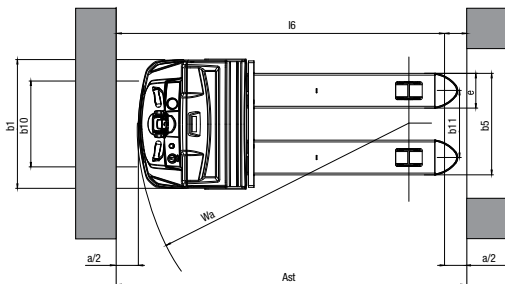

Ast = Wa-x+l6+a
 a = Safety clearance (200 mm)
 l6 = Pallet length



Convenient equipment bar option



Market-leading lifting height



Comfortable platform (PBP20N2R)

Drive

- **Powerful AC drive motor** is placed above the chassis plate, safeguarding it against the elements.
- **Oil-filled, sealed transmission** is shock-resistant, quiet and requires little maintenance.

Steering system

- **State-of-the-art tiller arm** offers the ultimate in ergonomic design, comfort and safety.
- **Small turning circle** together with compact chassis and excellent visibility means exceptional manoeuvrability.

Brakes

- **Regenerative braking** gives effective control, without brake wear, and extends shift life.
- **Parking brake** is automatically activated, when necessary, for extra safety on ramps.

Electrical and control systems

- **Programmable controller** adjusts acceleration, travel speed and braking to suit the application and operator – for greater versatility.
- **On-board diagnostics** and fault memory folder speed up servicing and help prevent damage.
- **High-efficiency electronic system** features waterproof components for maximum reliability – even in moist conditions.
- **Versatile battery compartment** accommodates DIN and BS size batteries with a variety of capacities for maximum compatibility with user's equipment and needs.

Operator environment and controls

- **Creep speed function and tiller arm lock bypass** maximise safety and control in confined spaces.
- **Unique crossbar design** deflects obstacles away from tiller arm and operator's hand, protecting both truck and operator.
- **Choice of two performance modes** via key switch enhances safety, energy efficiency and productivity.
- **Easy-to-operate controls** reduce operator fatigue and minimise mistakes to enhance safety.
- **Ergonomically shaped rubber hand grips** are comfortable and slip-free, allowing for easy reach of controls.
- **Battery discharge indicator** is fitted as standard for battery protection and monitoring of truck use.
- **Ground clearance** is only 35 mm – which makes foot trapping very unlikely.
- **Spacious, suspended foldable platform** on PBP20N2R allows operator to ride in comfort - maximum speed 6 km/h - during occasional longer travel.

Other features

- **RapidAccess features** allow quick and easy entry to all areas for checks and maintenance.

Options include:

- **Choice of drive and load wheels for different applications**
- **Single load wheels (standard on PBP16N2)**
- **Sealed inbuilt battery charger (except PBP20N2R)**
- **Pallet entry and exit rollers**
- **Wide variety of fork dimensions**
- **Cold store modification (class III, -35°C)**
- **Load backrest**
- **Multifunctional display with hour meter**
- **Equipment bar for mounting accessories**
- **375 Ah battery (PBP20N2 and PBP20N2R)**
- **Fingertip levers on tiller arm**
- **Rapid and/or double battery change device (PBP18N2 and PBP20N2)**
- **PIN code unit (PBP20N2R)**
- **LED Working light (PBP20N2R)**



PBP20N2R

When reliability is everything

Like any product bearing the Mitsubishi name, our materials handling equipment benefits from the huge resources and cutting-edge technology of one of the world's largest corporations. So when we promise you **quality, reliability** and **value for money**, you know it's a guarantee we have the power to deliver.

Every model in our comprehensive, award-winning range of forklift trucks and warehouse equipment is built to a high specification and is designed to keep on working for you... day after day... year after year... whatever the job... whatever the conditions.

To ensure your truck stays in constant productive action, we have a network of local dealers – hand-picked for their commitment to customer care... and backed up by the Mitsubishi Forklift Trucks organisation. No matter where you are, we have a dealer close by – ready and willing to meet your needs.

That friendly local service covers everything from identifying the perfect model and configuration for your application to providing competitive, flexible finance and maintenance packages, unbeatable warranties, long and short term hire, and highly responsive field service and repairs... as well as the industry's quickest and most reliable parts supply.

Only Mitsubishi can give you this combination of global engineering excellence and outstanding local support... only Mitsubishi offers you such a quality product at such an affordable price... and only Mitsubishi places reliability as high as you do in its priorities. Contact us now and see what we can do for you.

www.mitforklift.com



WESM 1475v2 (01/15)
© 2015 MCFE
Printed in The Netherlands

mitforklift@mcf.nl www.mitforklift.com

NOTE: Performance specifications may vary depending on standard manufacturing tolerances, vehicle condition, types of tyres, floor or surface conditions, applications or operating environment. Trucks may be shown with non-standard options. Specific performance requirements and locally available configurations should be discussed with your distributor of Mitsubishi forklift trucks. Mitsubishi follows a policy of continual product improvement. For this reason, some materials, options and specifications could change without notice.